



MATERIAL HANDLING PRODUCTS



One Million Square Feet
of Production Facilities

PT-40



PRECISION TELEHANDLER



PT40

STANDARD FEATURES

- Industrial Telehandler with 40,000 lb. (18,143.7kg) Capacity at 24-Inch (609.6mm) Load Center
- Compact Lowered Height, Can Lift 20 Tons (18,144kg) 20 Feet (6.1M)
- 88" (2.24M) Tall, 6' (1.82M) Wide, 8' (2.43M) Reach, 20' (6.1M) Lift, 27' (8.23M) to Jib Eye and 6 Tons (5,443kg) of Removable Counterweight
- All Boom Movements, Including TRUE VERTICAL LIFT and TRUE HORIZONTAL REACH are Controlled by a Single Joystick
- Fork Tilt is Auto-Leveling with a Manual Override
- Fine-Feathering Hydraulics Ensure Smooth and Precise Load Positioning
- Smooth Hydrostatic Drive is Controlled by a Comfortable Foot Treadle
- The Deep Reduction Planetary Wheel Hubs Generate 20,000 lbs. (9,071.85kg) of Tractive Effort and Can Propel a 20 Ton (18,144kg) Load Up a 24% Grade
- Radio Remote Control Allows Many Jobs to be Completed with Only One Operator



WIRELESS REMOTE CONTROL

All PT40 drive and lift functions can be controlled via wireless transmitter, allowing a single operator to observe the entire work environment without being confined to the operator's station.

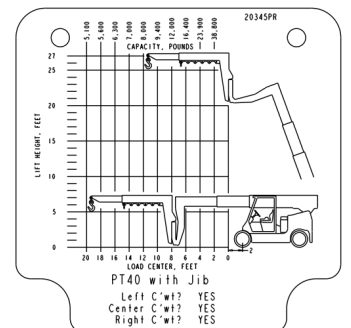
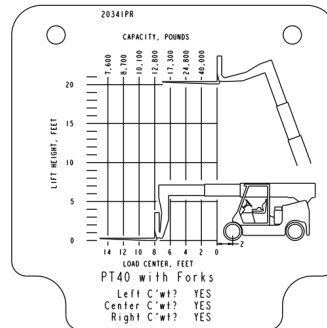
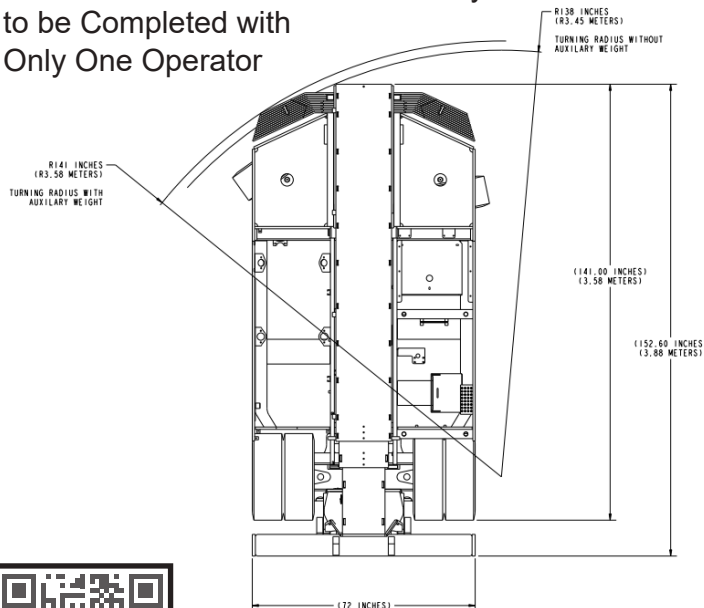

40,000 lb. (18,143.7kg) Capacity to 24" (609.6mm) Load Center

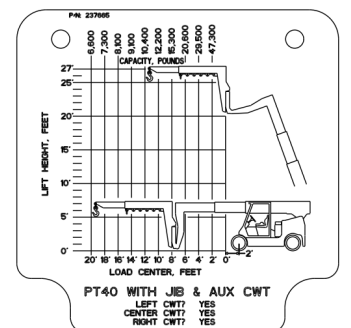
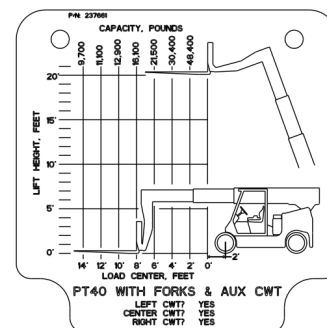

48,000 lb. (21,772.43kg) Capacity to 24" (609.6mm) Load Center



Scan the QR Code to Learn More!

PT40

Precision Telehandler

40,000 lb. (18,143.7kg) capacity at 24-inch (609.6mm) load center

TECHNICAL & DIMENSION DATA

MODEL	PT40
Engine	GM 3.0 L 91 hp at 3,000 rpm
Transmission	Hydrostatic, 0-6mph (0-9.67kph) infinitely variable
Hyd. System	Load sensing, pressure compensated
Hyd. Filtration	3 micron synthetic element
Electrical	Sealed IP66 Minimum

MODEL	PT40
Tires	28x10x22 in. (711x254x559mm), front duals, rear singles
Gradeability	24% with 40,000 lb. (18,143.7kg) load
Tractive Effort	20,000 lbs. (9,071.85kg)
Weights	40,700 lbs. (18,461.21kg) complete
- Jib and Rack	2,800 lbs. (1,270.06kg)
- Removable Counterweight	12,000 lbs. (5,443.11kg)
- Both Forks	1,600 lbs. (725.75kg)
- Bare Truck Weight	24,400 lbs. (11,067.65kg)
- Forks (2 Forks, 8' Long)	1,640 lbs. (743.89kg)
- Jib	2,650 lbs. (1,202.02kg)
- 3 Standard Rear CTWT's	12,000 lbs. (5,443.11kg)
- Hang-On Aux CTWT	4,300 lbs. (1,950.45kg)
- Jib / Forks Rack	680 lbs. (308.44kg)
- Hang-On Aux Weight Rack	470 lbs. (213.19kg)

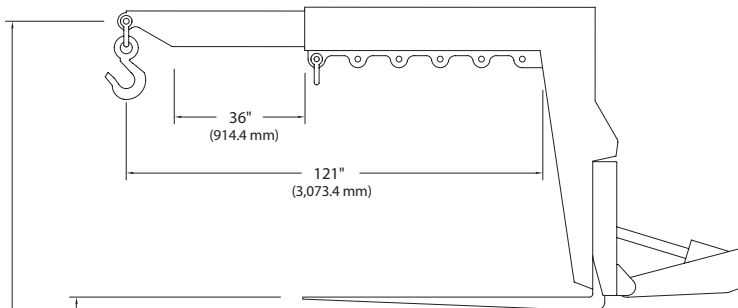

The specifications contained in this spec sheet are subject to change at any time without notice. Actual dimensions and performance data given herein may vary due to manufacturing tolerances.

OPTIONAL FEATURES

- Jib Boom
- Remote Control
- Aux Weight for 48,000 lb. (21,772.43kg) Capacity at 24-Inch (609.6mm) Load Center
- Special Paint – Available Upon Request

325"
(8,255 mm)

243"
(6,172.2 mm)

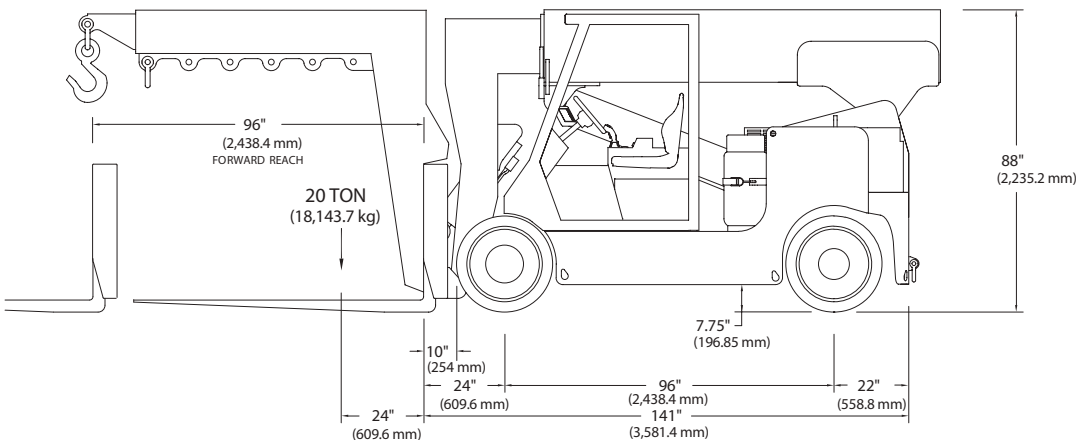

QUALITY

IS OUR FIRST PRIORITY



Exceptional Customer Support, Parts and Service

Landoll is committed to total customer satisfaction by providing products and services of the highest quality. Aftermarket parts and service is available world-wide through our factory trained dealer network and Landoll's service support department. Our 75,000 sq ft Parts Distribution Center ensures quick and accurate delivery of parts to keep your equipment up and running. Experience for yourself the reason that Landoll Material Handling Products are #1 in customer retention.

Proven Solutions for Storage & Specialty Handling Applications

Family owned and operated since 1963, we make quality our first priority. Our goal is to provide the best solution for your material handling needs. Bendi articulating, Drexel SwingMast® Narrow Aisle and Very Narrow Aisle forklifts provide that solution. Through increased utilization of space, improved productivity, greater flexibility and maximized efficiency. We stay on the edge of modern and innovative technology. We know that for our customers "Quality is Always a Bargain".



MATERIAL HANDLING
landoll.com/mhp

1900 North Street Marysville, KS 66508 · 800-428-5655 · forkliftsales@landoll.com

